

Thin Single Disc Swing Check Valve With Spring

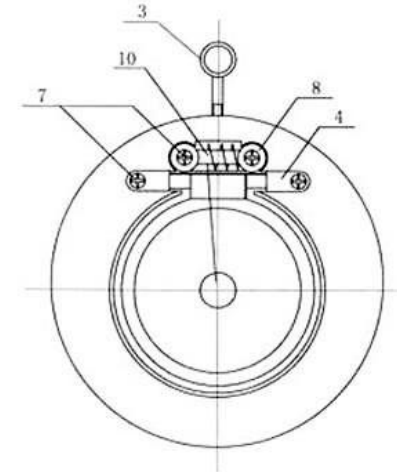

NO.	PART	MATERIAL
1	Body	SS304/SS316/WCB
2	Disc	SS304/SS316/WCB
3	Ring	Steel
4	Baffle	SS304/SS316/WCB
5	O-Ring	NBR/EPDM/VITON
6	O-Ring	NBR/EPDM/VITON
7	Bolt	SS304/SS316/WCB
8	Backing Plate	SS316/SS304
9	Spring	SS316/SS304
10	Shaft	SS304/SS316

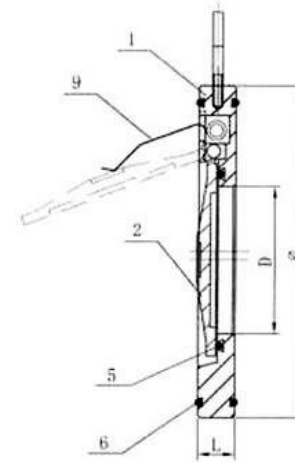

DESCRIPTION

- Working pressure: 1.0Mpa/1.6Mpa/2.5Mpa/4.0Mpa
- Working temperature:
 NBR: 0°C ~ +80°C
 EPDM: -10°C ~ +120°C
 VITON: -20°C ~ +180°C
- Face to face according to DIN, ANSI
- Flange according to EN1092-2, ANSI 125/150 etc.
- Testing: DIN3230, API598
- Medium: Fresh Water, Sea water, food stuff, all kinds of oil, acid, alkaline liquid etc.

DN(mm)		50	65	80	100	125	150	200	250	300	350	400
ΦD(mm)	PN10	107	127	142	162	192	218	273	328	378	438	489
	PN16	107	127	142	162	192	218	273	329	384	444	491
ΦE(mm)		32	40	54	70	92	114	154	200	235	280	316
L(mm)		14	14	14	18	18	20	22	26	28	38	44