

2pcs Thread End Ball Valve



NO.	Part	Material
1	BODY	A216-WCB/A351-CF8/A351-CF8M
2	SEAT	PTFE/RPTFE
3	BALL	SS304/SS304/SS316
4	GASKET	PTFE
5	CAP	A216-WCB/A351-CF8/A351-CF8M
6	STEM	SS304/SS304/SS316
7	THRUST WASHER	PTFE
8	PACKING	PTFE
9	GLAND NUT	304
10	HANDLE	304
11	SPRING WASHER	304
12	NUT	304
13	LOCK	304
14	HANDLE COVER	PLASTIC

DESCRIPTION

1. Investment castings for Body and Cap
2. Internal Entry Blow-Out Proof Stem
3. Pressure Rating:1000PSI (PN63)
4. Thread End: ANSI B2.1, BS21,ISO7/1
5. Working pressure: -25°C+180°C
6. Material: CF8M,CF8,CF3M,WCB
7. Lock Device (option)

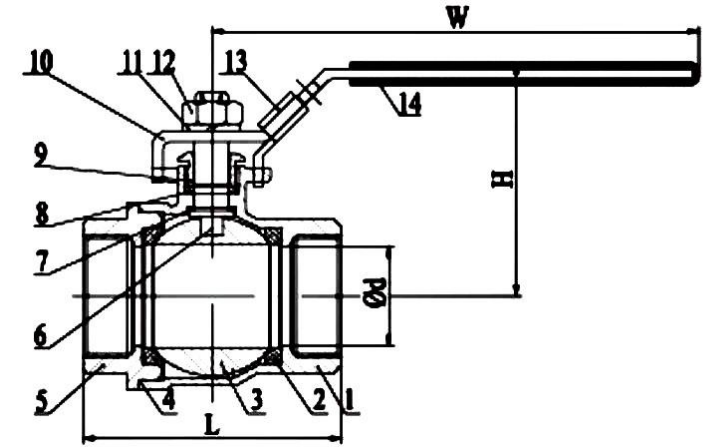

Size		Φd	L	H	W	N.M	KGS
DN6	1/4"	12.5	50	49	106	4	0.19
DN10	3/8"	12.5	50	49	106	4	0.19
DN15	1/2"	15	56	51	106	5	0.26
DN20	3/4"	20	66	58	116	8	0.41
DN25	1"	25	79	73	148	10	0.66
DN32	1-1/4"	32	91	79	148	14	1.00
DN40	1-1/2"	38	99	85	182	25	1.30
DN50	2"	50	121	95	182	40	2.10
DN65	2-1/2"	65	147	126	252	48	3.83
DN80	3"	76	173	138	252	80	5.74
DN100	4"	94	222	158	283	103	10.70