

1pc Flanged End Ball Valve



NO.	Part	Material
1	BODY	A216-WCB/A351-CF3/A351-CF8M
2	CAP	A216-WCB/A351-CF3/A351-CF8M
3	BODY GASKET	PTFE
4	BALL	SS304/SS304/SS316
5	SEAT	PTFE
6	STEM	SS304/SS304/SS316
7	THRUST WASHER	PTFE
8	ORING	VITON
9	STEM PACKING	PTFE
10	GLAND NUT	304
11	BELLEVLLE WASHER	301
12	NUT STOPPER	304
13	NUT	304
14	PLATE WASHER	304
15	LOCK	304
16	HANDLE	304
17	HANDLE COVER	PLASTIC
18	STOP PIN	304

DESCRIPTION

1. Investment Casting for Body and Cap
2. Internal Entry Blow-Out Proof Stem
3. Pressure Rating : 1/2"-2":PN16/25/40;2-1/2"-4":PN16
4. Size : DN6-DN50 (1/4"-2")
5. Flanged End:1/2"-2"(PN16/25/40):DIN2543/2544/2545;2-1/2"-4"(PN16):DIN2543
6. Mounting Pad: ISO 5211
7. Working Temperature : -25°C+180°C
8. Material : CF8 , CF8M , CF3M , WCB
9. Inspection Testing : API 598 , EN12266

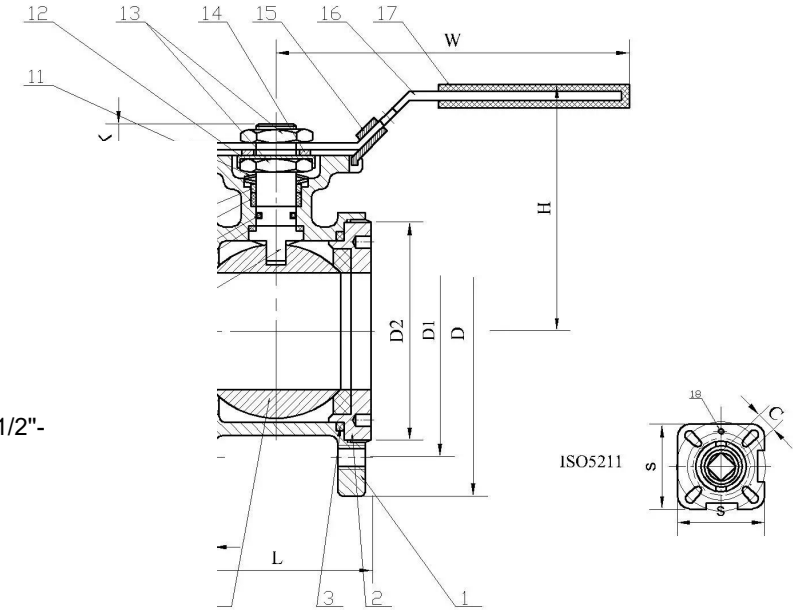

Size	D	L	D	D1	D2	B	F	H	W	C	ISO5211	Z-M	N.M	KGS	
DN15	1/2"	15	36	95	65	45	11	2	89	117	9	F03/04	4-M12	5	1.21
DN20	3/4"	20	38	105	75	58	11	2	94	117	9	F03/04	4-M12	8	1.53
DN25	1"	25	50	115	85	68	12	2	90	164	11	F04/05	4-M12	10	1.95
DN32	1-1/4"	32	53	140	100	78	14	2	100	164	11	F04/05	4-M16	14	3.1
DN40	1-1/2"	40	65	150	110	88	15	3	105	203	14	F05/F07	4-M16	18	4.18
DN50	2"	50	78	165	125	102	16	3	125	203	14	F05/F07	4-M16	25	5.37
DN65	2-1/2"	65	98	185	145	122	16	3	140	255	17	F07/F10	4-M16	48	10.1
DN80	3"	76	118	200	160	138	18	3	145	255	17	F07/F10	4-M16	75	12.3
DN100	4"	94	140	220	180	158	18	3	175	302	17	F07/F10	4-M16	110	19.4